

PLEASE READ THESE INSTRUCTIONS CAREFULLY BEFORE FITTING THIS KIT

If you have a problem, however small, call our Technical Department

Tel:- 01925 636950. Fax:- 01925 243111. Mon to Thurs 8.30 - 5pm.

Drawing A

FRONT VIEW

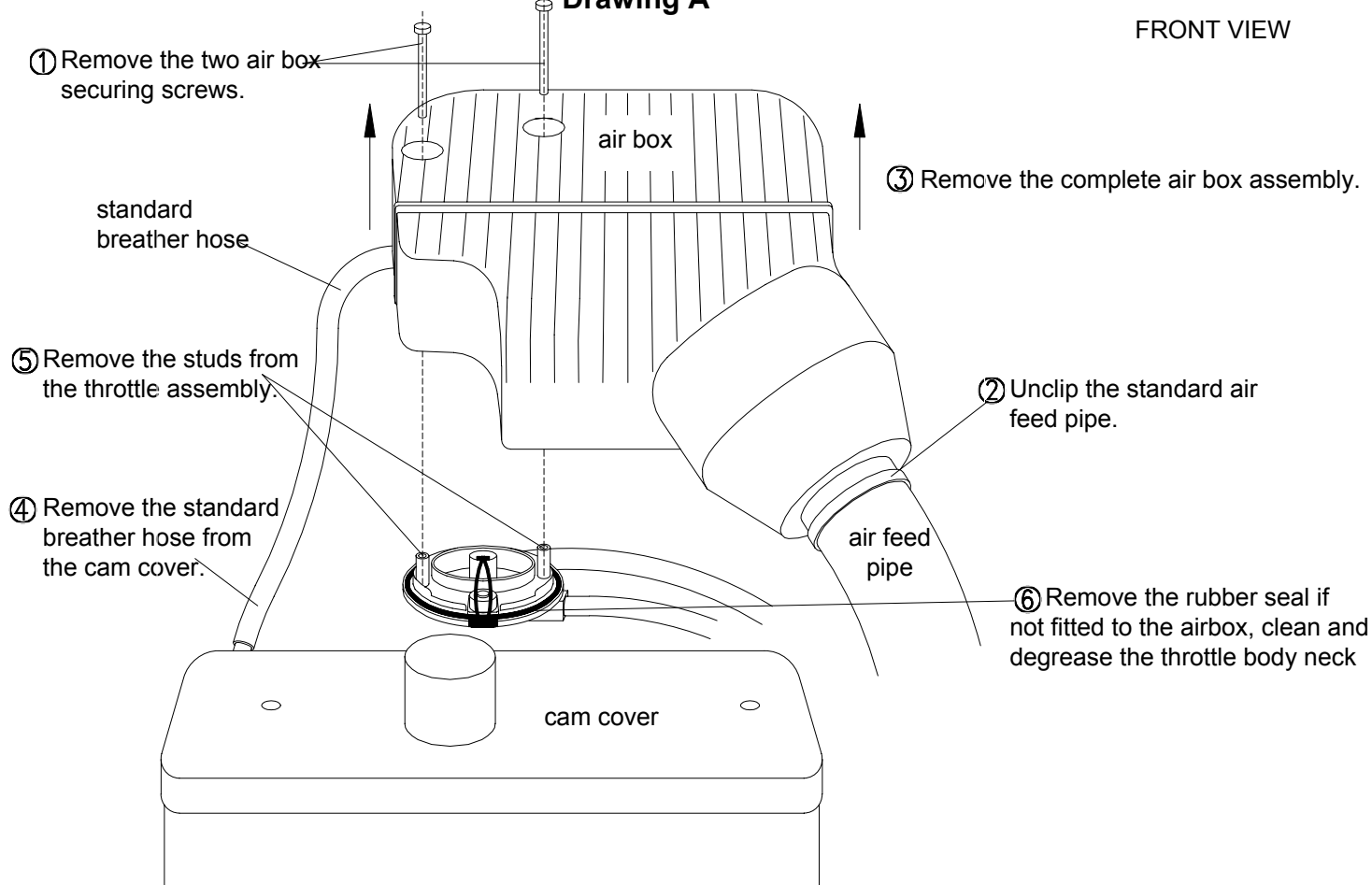

Drawing B

FRONT VIEW

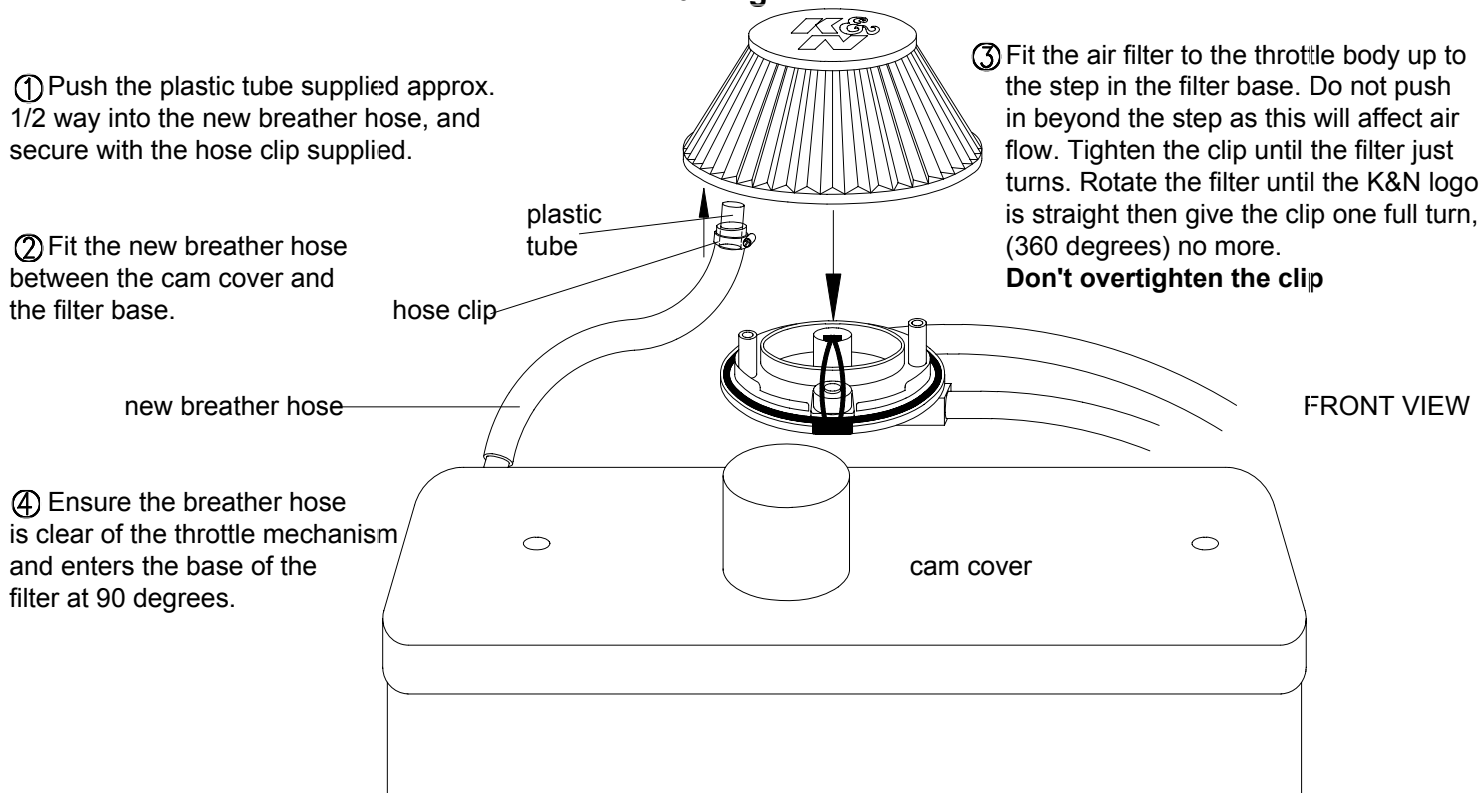

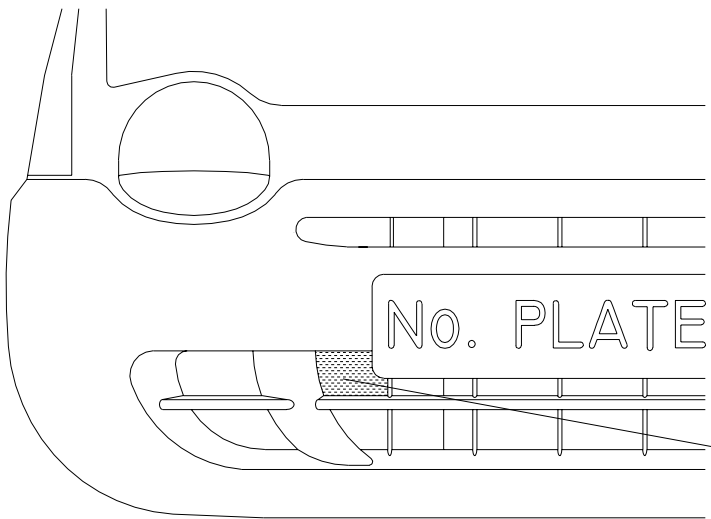

FRONT VIEW

Using all the necessary safety precautions remove the shaded section of the front bumper using a pad saw or similar

Drawing D

TOP VIEW

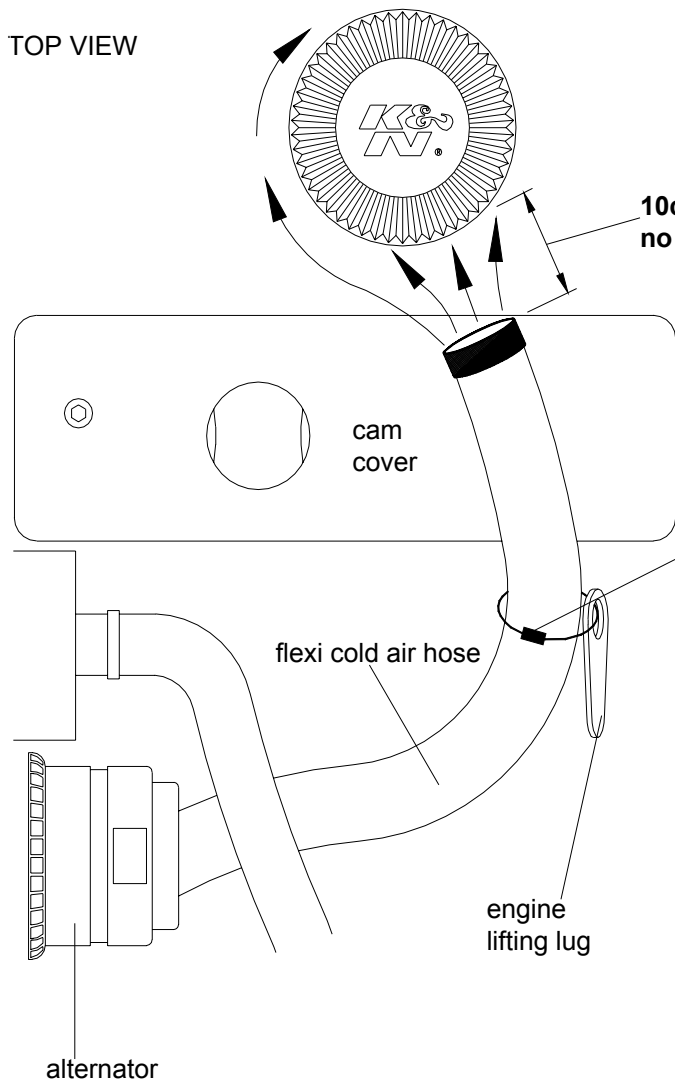

① Carefully lengthen the flexi cold air hose to 80cm/32".

② Feed the hose down between the engine and radiator and the below the alternator to the cut out section of the lower grille.

④ Position the top of the hose to finish approx. 10cm/4" from the filter and tie the hose to the engine lifting lug with the long plastic tie.

10cm/4"
no nearer

long plastic tie

flexi cold air hose

engine lifting lug

alternator

③ Pierce / drill a small hole (3mm) in the lower end of the flexi cold air hose and attach to the grille with a medium plastic tie.

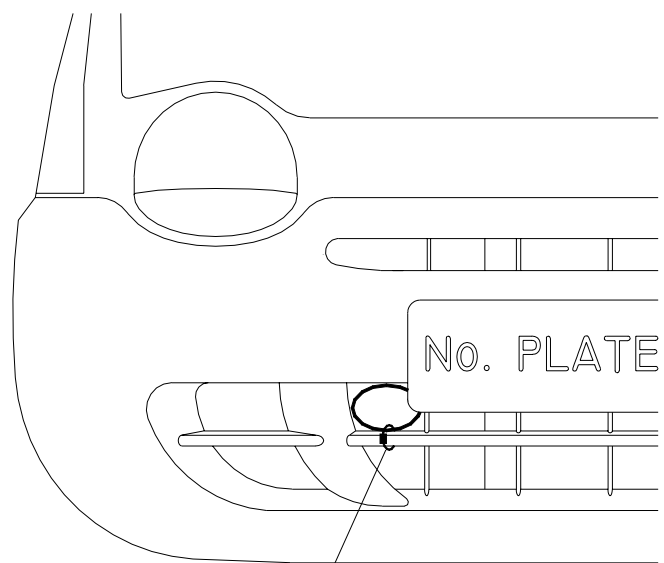

FRONT VIEW

Tuning.

CAT. Cars No adjustments required

An increase in fuel mixture may be required if further modifications are carried out.

Filter Maintenance.

Under normal conditions clean and reoil the filter at approx. 40,000 miles / 65,000km.

Use only K&N cleaner and oil and follow the instructions carefully.

K&N filters are pre-oiled ready to fit

The advantage of K&N's cold air intake system.

Cooler air being denser, will show positive improvements in power over filter systems that draw hot air from the engine bay.

This Kit Should Contain:

FITTING YOUR OWN 57i KIT

- 1 x Air Filter
- 1 x Cold Air Hose Assembly
- 1 x Breather Hose
- 1 x Instruction Pack:-
 - 1 x K&N window sticker
 - 1 x Filter Maintenance Sheet
 - 1 x Million Mile Warranty
 - 1 x Leaflet
- 1 x Fixing Kit containing:-
 - 1 Small Plastic Tube
 - 1 x #10 Hose clip
 - 1 x Long Cable Tie
 - 1 x Medium Cable Tie
 - 1 x 100/120 Hose clip
 - 1 x Instruction Sheet

If not **it is essential** that the person fitting the kit (e.g. mechanic) **carefully follows these particular instructions** even if he has fitted K&N kits before. This will save you both time and money. kits incorrectly fitted may show a loss in performance e.g. the positioning of the essential cold air hose, (flexi expandable and rubber hoses are used).

A final check under the bonnet, by yourself with the instructions, would seem sensible