

PLEASE READ THESE INSTRUCTIONS CAREFULLY BEFORE FITTING THIS KIT.

If you have a problem, however small, call our Technical Department.

Tel:- 01925 636950. Fax:- 01925 243111. Mon - Thurs 8.30 - 5pm.

- 1) Remove the complete air filter assembly, including the two supporting brackets (two screws at each end of the slam panel).
- 2) Remove the rubber intake hose from the air box.
- 3) **See drawing A&B**, feed the rubber hose downwards between the radiator and the intercooler. You may find it easier to push down if the hose is turned as in **Drawing A**. It can then be turned to its correct position as **drawing B**.
- 4) **Cold air system.**
Using a plastic tie attach the hose to the vertical metal support, **drawing B&C**, **don't overtighten the clip as it may compress the hose**.
- 5) The bottom of the hose should stay in place, but if you have a problem use the other plastic tie around the grille section (form a loop around the hose first).
- 6) Additional cold air can be achieved by removing a section from the black plastic screen located under the slam panel. **Drawing D**.
- 7) **Tuning.**
The engine should not require any further modifications.
- 8) **Filter maintenance.**
Under normal conditions, clean and reoil the filter at approx. 40,000 miles 65,000 km. **Use only K&N cleaner and oil** and follow the instructions carefully.

K&N filters are pre-oiled ready to fit

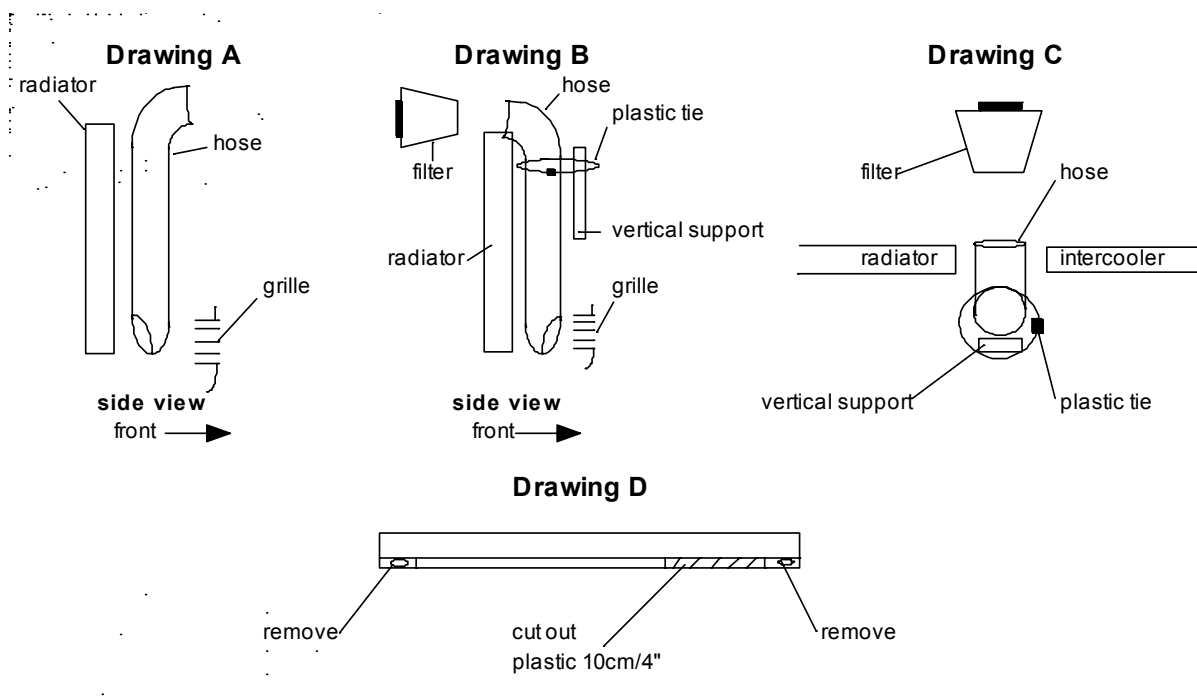

The advantage's of K&N's cold air intake system

Cooler air being denser will show positive improvements over systems that draw hot air from the engine bay.

This Kit Should Contain :-

- 1 x Air filter.
- 1 x Instruction sheet.
- 1 x Instruction pack:-
 - 1 x Filter maintenance sheet.
 - 1 x K&N window sticker.
 - 1 x Million mile warranty card.
 - 1 x Leaflet.
- 1 x Fixing Kit:-
 - 1 x Hose Clip #44
 - 2 x Plastic cable tie (14" long).

**IMPORTANT INSTRUCTIONS
FOR ROUND ENTRY
CLAMP ON AIR FILTERS**

Gently tighten the hose clip to the point where the filter will just rotate on the pipe or intake flange. Reposition the K&N logo straight, then **give the clip two turns i.e. 360, no more.**

FITTING YOUR OWN 57i KIT

If not, **it is essential** that the person fitting the kit (e.g. mechanic) **carefully follows these particular instructions** even if he has fitted K&N kits before. This will save you both time and money. Kits incorrectly fitted may show a loss in performance e.g. the positioning of the essential cold air hose, (flexi expandable and rubber hoses are used).

A final check under the bonnet, by yourself, with the instructions, would seem sensible.

Please Note:

On some Turbo cars there can be an increase in noise levels on deceleration once the airbox has been removed. This is normal.