

PLEASE READ THE INSTRUCTIONS CAREFULLY BEFORE FITTING THE KIT.

If you have a problem, however small, call our Technical Department.

Tel:- 01925 636950. Fax:- 01925 243111. Mon to Thurs 8.30 - 5pm.

- 1 Remove the plug from the Air Flow Meter (**AFM**). Release the hose on the intake pipe and remove the air box lid. Release the three remaining air box retaining screws and remove the air box base.
- 2 Remove the **AFM** from the air box lid and fit the new adaptor and gasket to the AFM with the four countersunk screws supplied.
- 3 Fit the mounting bracket to the **AFM** with the two screws supplied.
4. Cut out and position the template, tape in place, centre punch the two points and drill two holes 8.5mm diameter. Finally fit the rubber mountings with the washers and nuts supplied.
Drawing A.
- 5 Fit the **AFM** to the intake hose, **but do not fully tighten the clip** until the bracket is fixed to the rubber mountings.
- 6 Fit the air filter, keeping it square to the adaptor. Tighten the clip until the filter just moves, then give one full turn (360 degrees). No more. **Don't overtighten the clip.** Replace the plug into the **AFM**.
- 7 **Cold air system**
Carefully expand the flexi cold air hose to approximately 47cm / 19". Position the cold air hose to finish approximately 10cm/4" from the filter (**no nearer**), and secure with a plastic tie. **Drawing B.**
- 8 The position of the other end of the cold air hose will vary from model to model. On some models there is a small removable section, on others you will have to cut out a small section from behind the grille. Finally secure the hose with a plastic tie to the nearest location. **Drawing C.**
- 9 **Tuning.**
We suggest a simple **CO** test is carried out, as some cars may be set weaker than the standard setting. The **CO** figure should not be set at more than **0.5%** above the manufacturers recommended figure.
- 10 **Filter maintenance.**
Under normal conditions clean and reoil the filter at approx. 40,000 miles / 65,000 Km.
Use only K&N cleaner and oil and follow the instructions carefully.

K&N filters are pre-oiled ready to fit.

The advantage's of K&N's cold air intake system.

Cooler air being denser, will show positive improvements in power over filter systems that draw hot air from the engine bay.

This Kit Should Contain :-

- 1 x Clamp-on filter.
- 1 x Bracket.
- 1 x Cold air hose assembly.
- 1 x Instruction sheet.
- 1 x Instruction pack:-
 - 1 x Filter maintenance sheet.
 - 1 x K&N window sticker.
 - 1 x Million mile warranty card.
 - 1 x Leaflet.
- 1 x Fixing kit containing :-
 - 1 x Air flow meter adaptor.
 - 1 x Gasket.
 - 1 x #48 Hose Clip.
 - 4 x M6 Hex head screws.
 - 4 x Flat Metal Washers
 - 2 x M8 x 16 hex screws.
 - 4 x $\frac{5}{16}$ spring washers.
 - 4 x $\frac{5}{16}$ UNF hex nuts.
 - 2 x Rubber mountings.
 - 2 x Plastic cable ties (14" long).

FITTING YOUR OWN 57i KIT

If not, **it is essential** that the person fitting the kit (e.g. mechanic) **carefully follows these particular instructions** even if he has fitted K&N kits before. This will save you both time and money. Kits incorrectly fitted may show a loss in performance e.g. the positioning of the essential cold air hose, (flexi expandable and rubber hoses are used).

A final check under the bonnet, by yourself, with the instructions, would seem sensible.

suspension turret

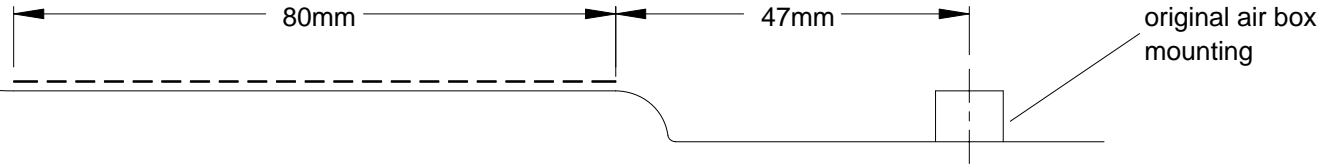

Cut the template making sure the base line is straight.

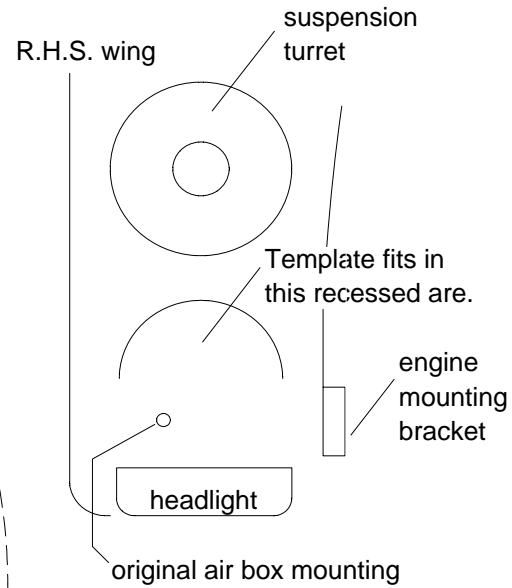
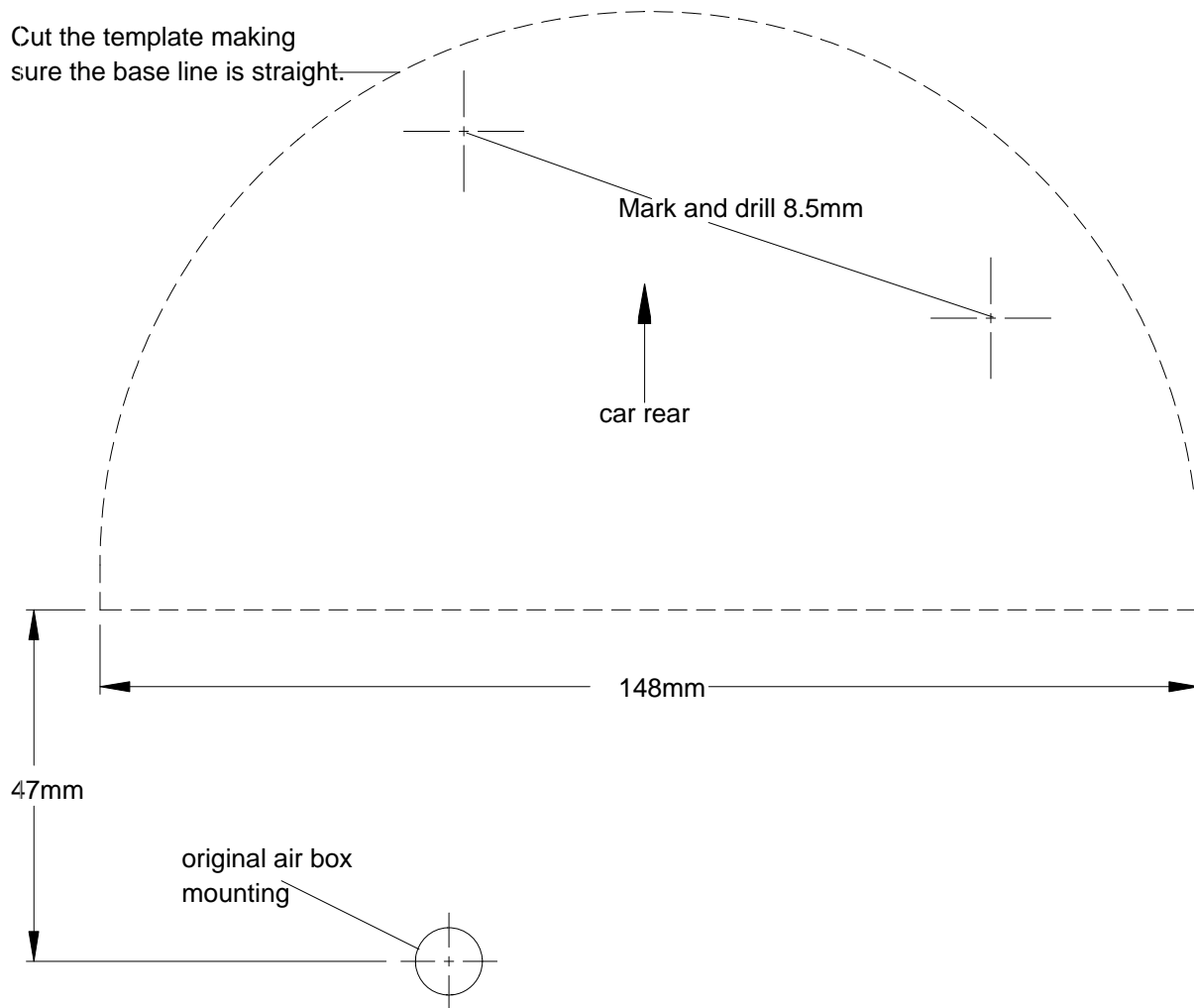

Drawing B

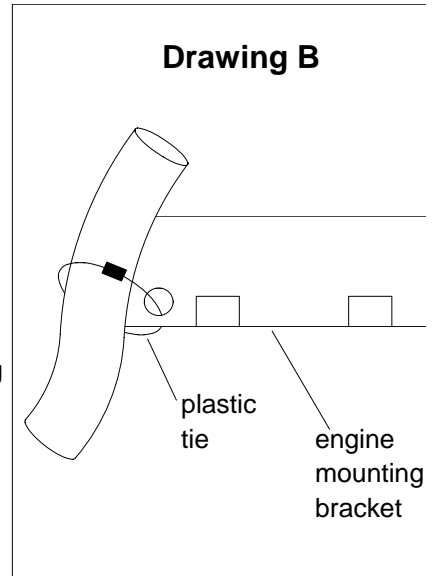

Drawing C

